

Cover Tamper Switch

Specifications

Contact Ratings:	5.0A @ 125/250 VAC 2.5A @ 24 VDC
Overall Dimensions:	1 ¹ / ₄ " H x 2" W x 3 ³ / ₄ " D
Operating Temperature Range:	32° to 120° F (0° to 49°C)
Shipping Weight:	0.025 lb.

NOTICE: This manual should be left with the owner/user of this equipment.

CAUTION

Do not leave unused wires exposed. Do not use in potentially explosive atmospheres.

General Information

This cover tamper switch mounts to all System Sensor WFD, WFDT, OSY2 and PIBV2 terminal block units. Cover removal produces a switch output. The unit will reset when the product cover is reinstalled.

Installation Guidelines

Before installing any cover tamper switch, be thoroughly familiar with:

- NFPA 72: National Fire Alarm Code
 - NFPA 13: Installation of Sprinkler Systems, specifically section 3.17.
 - NFPA 25: Inspection, Testing and Maintenance of Sprinkler Systems, specifically chapters 4 and 5.
- Other applicable NFPA standards, local codes and the requirements of the authority having jurisdiction.

Failure to follow these directions may result in failure of the device to report an alarm or trouble condition. System Sensor is not responsible for devices that have been improperly installed, tested or maintained.

Mounting Instructions

1. Install switch mounting bracket onto terminal block using the 2 screws provided, shown in Figure 1.
2. Snap the switch onto the switch mounting bracket in position shown in Figure 1.

Figure 1. Assembly Diagram:

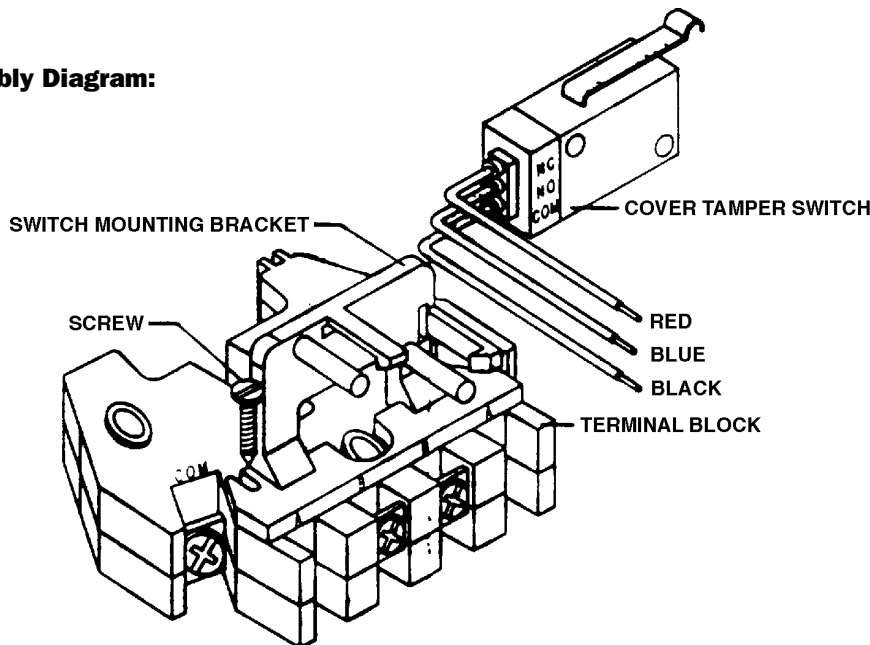

A78-1661-00

⚠ WARNING

High voltage. Electrocution hazard. Do not handle live AC wiring or work on a device to which AC power is applied. Doing so may result in severe injury or death.

NOTE: Where one wire already exists under the terminal plate, connect the cover tamper wire under the opposite side of the terminal plate.

2) When connected to a listed sprinkler/fire alarm control panel, the initiating circuit must be non-silenceable.

Field Wiring

1) Wire as required per wiring diagram (Figure 2), placing the stripped wire lead under the correct terminal plate. Extra wire lead should be clipped and terminated with a wire nut to avoid shorting to housing.

Figure 2. Field Wiring:

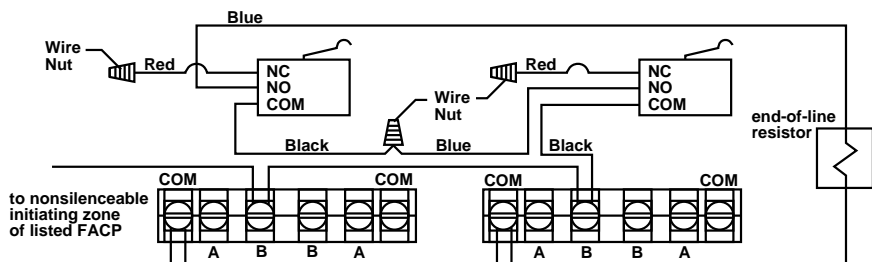

Typical Fire Alarm Control Panel Connection

Wire Code:	
Waterflow or Supervisory Switch:	
Com to B = Open Circuit	(Non Alarm Condition)
Com to A = Closed Circuit	
Cover Tamper Switch:	
Black / Blue: Open	(Cover Off)
Black / Red: Closed	

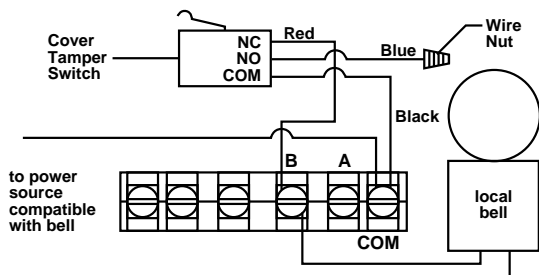

Typical Local Bell Connection

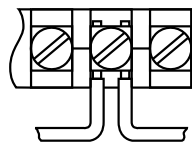

Break wire as shown for supervision of connection. DO NOT allow stripped wire leads to extend beyond switch housing. DO NOT loop wires.

NOTE:
Local bell will activate when cover is removed.

A78-1662-01

Operational Testing

Always notify a central station monitoring waterflow or supervisory switch alarms before repairing, maintaining, or testing cover tamper switch devices.

- 1) Replace the cover and tighten the security screws with the security wrench. Store the wrench in a secure place.
- 2) Verify that circuit has reset by checking FACP.

Three-Year Limited Warranty

System Sensor warrants its enclosed cover tamper switch to be free from defects in materials and workmanship under normal use and service for a period of three years from date of manufacture. System Sensor makes no other express warranty for this cover tamper switch. No agent, representative, dealer, or employee of the Company has the authority to increase or alter the obligations or limitations of this Warranty. The Company's obligation of this Warranty shall be limited to the repair or replacement of any part of the cover tamper switch which is found to be defective in materials or workmanship under normal use and service during the three year period commencing with the date of manufacture. After phoning System Sensor's toll free number 800-SENSOR2 (736-7672) for a Return Authorization number, send defective units postage prepaid to: System Sensor,

Repair Department, RA # _____, 3825 Ohio Avenue, St. Charles, IL 60174. Please include a note describing the malfunction and suspected cause of failure. The Company shall not be obligated to repair or replace units which are found to be defective because of damage, unreasonable use, modifications, or alterations occurring after the date of manufacture. In no case shall the Company be liable for any consequential or incidental damages for breach of this or any other Warranty, expressed or implied whatsoever, even if the loss or damage is caused by the Company's negligence or fault. Some states do not allow the exclusion or limitation of incidental or consequential damages, so the above limitation or exclusion may not apply to you. This Warranty gives you specific legal rights, and you may also have other rights which vary from state to state.